	按摩床电机 (内置驱动器)	Output power 输出功率: 2W	Weight 重量: 182g (Approx.)
	Brushless DC Motor-Typical Application 直流无刷电机-典型应用 Home Application: White Goods, Small Appliance, Fanner, Electric Curtain 家用电器: 白色家电, 小家电, 电风扇, 电动窗帘 Medical Apparatus: Medical Pump, Surgery Tools, Medical Stirrer, centrifugal Machine 医疗器械: 医疗泵, 手术器械, 搅拌机, 离心机 Power Tools: Screwdriver, Drill, Air Compressor 电动工具: 电动螺丝批, 电钻, 气体压缩机 Business Equipment: Printer, Copier, Projector, ATM, Vending Machine 商业设备: 打印机, 复印机, 投影机, ATM 机, 售卖机 Personal Care: Hair Dryer, Electric Shaver, Massager 个人护理: 风筒, 电动须刨, 按摩器		

Model 型号	电压 Voltage (V)		No Load 空载		Rated Load 额定负载			环境温度	防护等级	
	Operating Range	Rated	Speed (rpm)	Current (A)	Torque (mNm)	Speed (rpm)	Current (A)	Output P. (W)	Ambient temperature	Protection Degree
FBL-36H02051RS-YTJ	16-28	24	600	0.054	45	500	0.25	2	-20°C-55°C	IP44

Characteristics: CW/CCW Both rotation, Signal function available, Locked rotor protection, Low inertia, Low noise, Low EMI, Long life

Over 10000hrs 特征: 双转向信号功能, 锁定保护, 低惯量, 低噪音, 低电磁干扰, 超长寿命 10000 小时以上。

Outline Drawing 外形图: (1、红色线: “+”; 2、绿色线: 转速信号输出; 3、黄色线: 正/反控制; 4、黑色线: “-”; 5、蓝色线: PWM 速度控制; 6、白色线: 刹车)

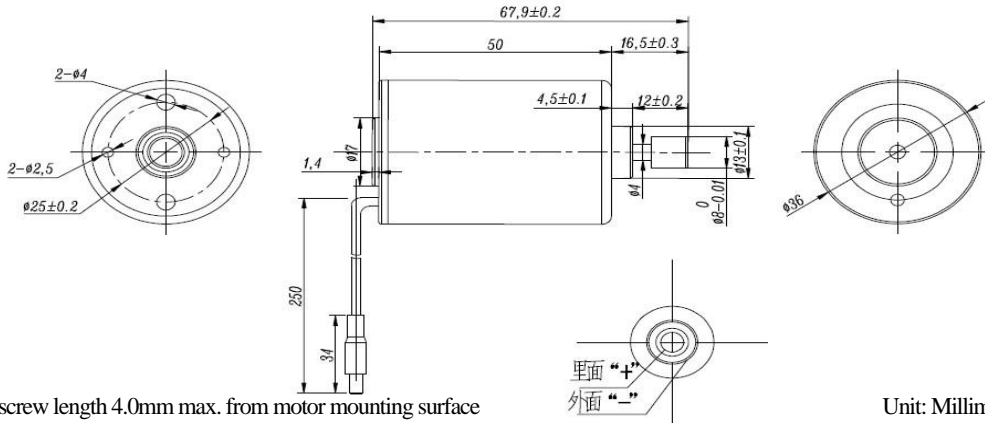

Usable machine screw length 4.0mm max. from motor mounting surface

Unit: Millimeter

Performance Curve 性能曲线:

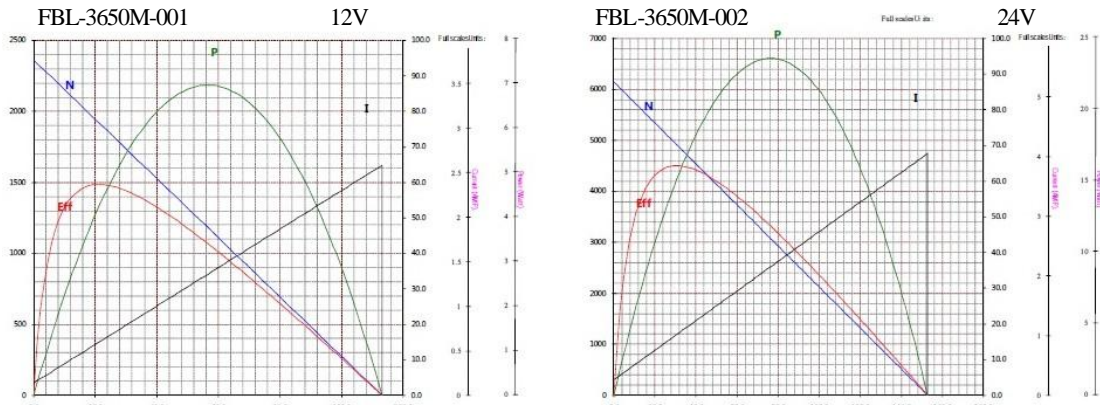

地址: 上海奉贤区奉浦工业区同谊路 88 号

ADD: No.88, Tongyi Road, Fengpu Industrial park, Fengxian District, Shanghai, China.

电话 Tel.: +86-21-57436767 传真 Fax.: +86-21-57436611 网址 Web site: <http://www.f-021.cn> 邮箱 Email: zhc@F-021.cn