

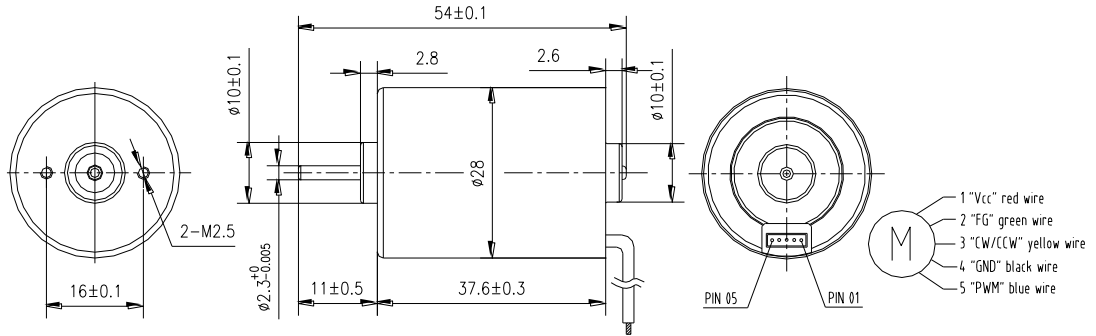

**PM DC PLANETARY GEAR MOTOR**  
 产品特点和用途：  
 直径 28mm 的行星齿轮减速器  
 适合于要求直径小，中心出轴，以及出力大的仪

※ 电机外形尺寸 Motor Overall Dimension



※ 电机主要技术参数 Motor Technical Data

Model 型号	电压 Voltage (V)		No Load 空载		Rated Load 额定负载				Starting 起动	
	Operating Range	Rated	Speed (rpm)	Current (A)	Torque (mNm)	Speed (rpm)	Current (A)	Output P. (W)	Torque (mNm)	Current (A)
FBL-2838K	8-26	12	4480	0.11	12.0	3200	0.57	4	42	1.72
FBL-2838H	8-26	24	3500	0.08	18.0	3000	0.57	5.6	63	1.83

※ 行星减速器外形尺寸 Planetary Gearbox Overall Dimension

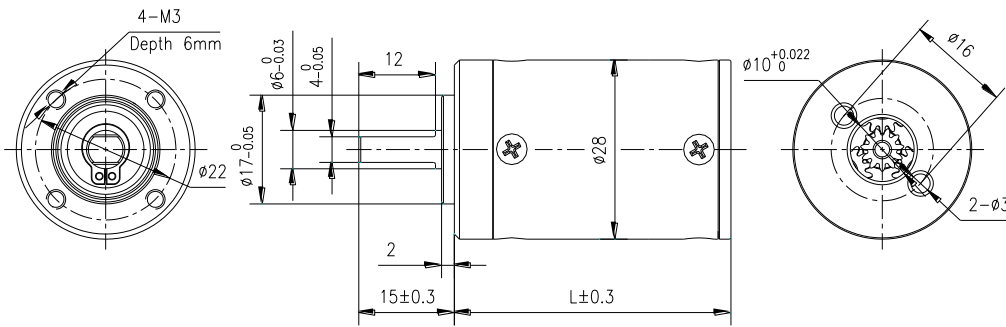

※ 配置电机的完整型号:FBL-2838HRX□( □内填写减速比)

减速比 Reduction Ratio	3.7	5.2	14	19	27	51	71	100	139	189	264	369	515	721
减速级数 Reduction stage	1	1	2	2	2	3	3	3	3	4	4	4	4	4
齿轮箱长度 L (mm) gearbox length	27.5	27.5	35.5	35.5	35.5	43.5	43.5	43.5	43.5	51.5	51.5	51.5	51.5	51.5
空载转速 (Rpm) No-load speed	946	673	250	184	130	69	49	35	25	19	13	9.5	6.8	4.9
额定转速 (Rpm) Rated speed	811	577	214	158	111	59	42	30	22	16	11	8.1	5.8	4.2
额定扭矩 (N.m) Allowance torque	0.067	0.094	0.252	0.342	0.486	0.788	0.98	0.98	0.98	1.47	1.96	1.96	1.96	1.96
瞬间允许扭矩 (N.m) torlerance torque	0.59	0.59	0.98	0.98	0.98	1.47	1.96	1.96	1.96	2.94	3.92	3.92	3.92	3.92